



Olive Oil Recovery

Machines and process lines from GEA Westfalia Separator Group

More than 6000 years ago, the olive had already been discovered in Asia Minor as a versatile fruit for eating and cosmetics. The special fatty acid composition promotes health and makes the “nectar of the gods” one of the most prized natural products today.



Content

- 4 The Latest Chapters in a Long Success Story
- 6 Solutions for all Country-Specific Production Methods
- 8 Comparison of 2-Phase and 3-Phase Systems
- 10 Continuous or Batch Process
- 12 Repasso, Pomace and Process Water Treatment
- 14 Acceptance and Cleaning
- 15 Mills
- 16 Malaxers
- 17 Accessories
- 18 Decanters
- 20 Separators
- 23 Service

The Latest Chapters in a Long Success Story

Since the 1930s, GEA Westfalia Separator Group has supported industrial production of olive oil. With innovative developments such as the environmentally friendly 2-phase system, the company now sets global standards for efficiency and profitability.

GEA Westfalia Separator Group can look back on more than 120 years of tradition. Today, the company is the global leader in mechanical separating technology. Its developments are used in a wide range of areas – in the beverage and dairy industries, in recovering and processing oils and fats, as well as in chemicals, pharmaceuticals, biotechnology and starch technology. Other applications include marine engineering, energy, oil fields and industry. The ecological dimension is particularly noticeable in the field of environmental technology. Based on this extensive experience over many years, GEA Westfalia Separator Group develops and builds customized centrifuges especially for the olive oil industry. If required by the customer, we can also supply entire process lines, incorporating all the components from acceptance of the olives through to oil polishing.

Olive oil is one of the oldest of all cultural assets. It is thought that olive trees were being cultivated as long as 6000 years ago in Asia Minor. Around 1600 B.C. the Phoenicians spread the use of olives through Crete and Egypt to the rest of the Mediterranean region. By now, nutritionists have long since discovered what makes the “nectar of the gods” so valuable. The native Extra olive oil is ascribed the best composition of saturated and unsaturated fatty acids, making it the best of all edible oils.

Industrial production of olive oil has been supported by GEA Westfalia Separator Group since back in the 1930s. Until well into the 1970s, after crushing, stirring and heating it was standard practice to squeeze the olive using hydraulic presses and to separate the liquid obtained into oil and water phases in small disk separators or static sedimentation tanks – a very complex procedure with relatively low outputs.

While initially only separators were supplied to the industry, later on also powerful 3-phase decanters were used.

3-phase technology involved diluting the olive pulp with water, enabling the oil to be separated off from the solid matter and water – an economical method, but one which, because of its requirement for huge volumes of fresh water, placed a significant burden on the environment. The quantities of waste water also proved to be an ecological problem.

Environmentally-friendly 2-phase system

The crucial advance came in the form of the 2-phase system. This was a method developed in the early 1990s by GEA Westfalia Separator Group, which uses no added water for dilution and produces correspondingly less waste water. As well as reducing the incidence of waste water, the high yield and premium product quality are further benefits of this method.

The decanters with GEA Westfalia Separator **cetec** technology introduced in 2001 brought a further increase of yield. In addition, special methods are now used to prepare the pomace and the process water.

The latest development is the completely new decanter generation GEA Westfalia Separator **ecoforce**. They convince with outstanding performance data and separation efficiency, minimum energy consumption, topmost availability, identical design of all model sizes combined with flexible equipment possibilities.

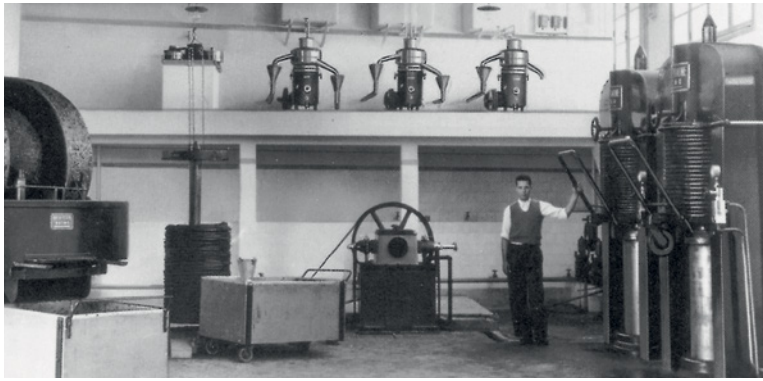

Polishing separators from GEA Westfalia Separator Group ensure premium quality oils with no residue.



Decanters are at the heart of the recovery process. GEA Westfalia Separator models support both 2-phase and 3-phase processes.

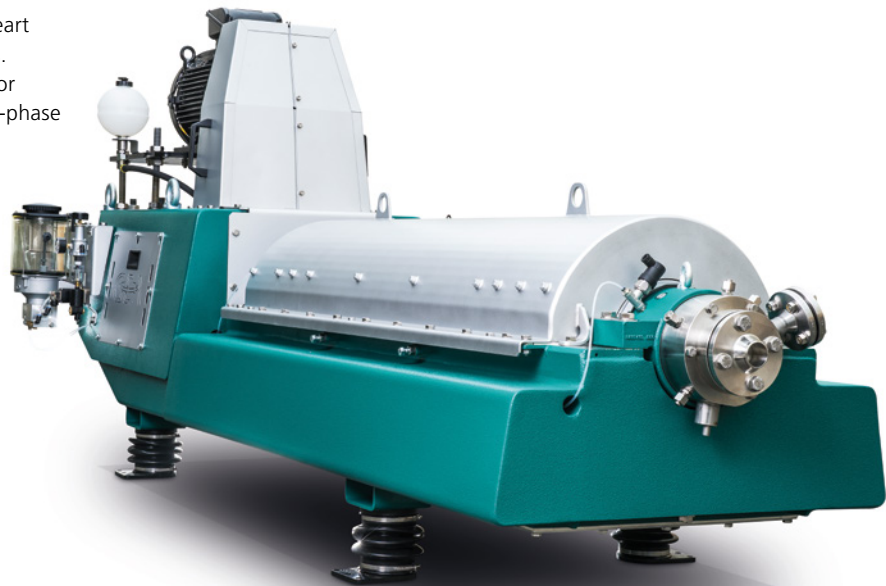

Solutions for all Country-Specific Production Methods

Process lines need to meet different requirements depending on national traditions and sizes of the harvest. GEA Westfalia Separator supplies tailored solutions to support all production methods.

At present, around two and half million tons of olive oil are produced every year. More than 80 percent of this figure is accounted for by countries in the European Union. The most important growing countries are Spain, Italy and Greece. However, the trend towards olive oil has led to rising production figures in other Mediterranean countries, the Middle East, Africa and elsewhere in the world. Turkey, Syria, Morocco, South Africa, Australia, Argentina and Chile are particularly important.

Spain is the largest international producer of olive oil. Growing and harvesting are mainly carried out on an industrial scale on the Iberian Peninsula. Olives from farmers, many of whom are grouped into production collectives, are brought to the mill and collected in huge silos by type. Depending on the weather, the level of soiling of the olives can be relatively high. Because of this, plants with a much higher cleaning, washing and buffer capacity than production capacity are required. The olive oil is produced using a continuous process with 2-phase decanters. By comparison, other production countries have small to medium harvests. The olives are also relatively to extremely clean. The result of this is that the cleaning, washing and buffer capacity matches the plant output. Thus, if the output of a decanter is 100 tons per day, the washing capacity is also designed for 100 tons. By contrast, in Spain the washing capacity is normally around twice the decanter output.

Despite the similar conditions in terms of the quantities to be processed and the level of soiling, there are differences in how the olives are processed in the individual growing countries outside Spain. Depending on local traditions, requirements and the opportunities for further treatment of the pomace, both 2-phase and 3-phase decanters can be used.

There are much greater differences between individual growing regions when it comes to the question of the extent to which production of the oil is grower-based. There are countries, such as Greece and Turkey, where a batch production method is predominantly used. The reason for this is that here the individual farmers produce their own oil from the olives they have grown and sell it themselves. They bring their olives to the mill and wait until they have been processed.

In other countries, such as Australia, Argentina and also the USA, the oil is produced continuously. This means that the olives are only separated by types before processing.

Depending on requirements, GEA Westfalia Separator Group supplies both 2-phase and 3-phase decanters to support all country-specific production methods – whether they are continuous or batch methods. The ratio of washing and cleaning capacity to processing capacity can be individually adjusted according to specific requirements. The company's services cover planning, engineering and process monitoring for plants for between 20 and 240 tons of olives per day.

- Continuous method
- Batch method
- 2-phase and 3-phase systems
- Configurations for capacities of between
- 20 and 240 tons of olives per day

Harvesting and processing methods for the olives differ according to the growing region.



Comparison of 2-Phase and 3-Phase Systems

GEA Westfalia Separator Group supplies appropriate 2-phase or 3-phase decanters to support both methods. In every case, the result is maximum yield of premium quality product. However, the considerably lower consumption of fresh water makes the 2-phase system significantly more environmentally friendly.

What both processes have in common is that the olives are initially reduced to a pulp. With 3-phase technology, this olive pulp must be diluted with warm water for a layer to form between the oil and solids in the decanter. This is the only way to achieve the subsequent separation into oil phase, pomace and waste water. Depending on the type of olive, the required volume of water is 15 to 20 percent, in rare cases as much as 50 percent. The amount of loaded waste water produced by this process is correspondingly high. Cleaning the waste water is also very demanding and cost-intensive.

In the environmentally-friendly 2-phase system, the preliminary treatment of the olives is essentially the same as in a 3-phase system. However, the fruits are milled smaller and malaxed for longer. After defoliation, the olives are milled in hammer mills with mesh sizes of 5 to 6 mm and the pulp is malaxed (at a maximum of 27 °C for cold pressed olives) to allow the oil to be separated from the fruit particles. For the subsequent 2-phase separation, GEA Westfalia Separator Group developed a decanter with a special scroll, which separates the pulp into oil on the one hand and pomace and water on the other hand. In addition to the ecological issues, the 2-phase system is also impressive from an economic perspective. It ensures the best possible oil quality by retaining the highest possible polyphenol content. The taste is intense, because many flavours and ingredients are washed out to a much lesser extent due to the addition of less water. At the same time, these oils have an exceptionally long shelf life.

All the advantages at a glance

- Maximum oil yield
- Premium product quality
- Minimum waste water volumes (in 2-phase system)
- 1 – 2 percent additional yield thanks to innovative GEA Westfalia Separator **cetec** technology
- Robust technology, Made in Germany
- Individually adjustable machine parameters
- Easy handling
- High efficiency – rapid amortization

Advantages of the 2-phase process

- No addition of dilution water necessary in most cases
- The olive oil obtained in the 2-phase process contains all natural constituents of oil (polyphenols), giving the oil a more intense taste
- Solid / water mixture can be processed relatively easily (e. g. for pit separation, water separation and olive oil recovery)
- No separate waste water phase in decanter

Advantages of the 3-phase process

- Dry solids are easy to transport
- Solid quantity is only 50 percent of the feed quantity
- Established infrastructure for processing of solids in traditional industry

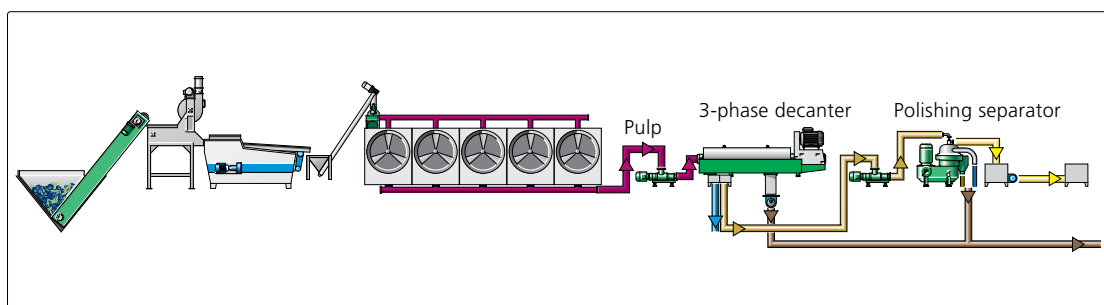

3-phase process

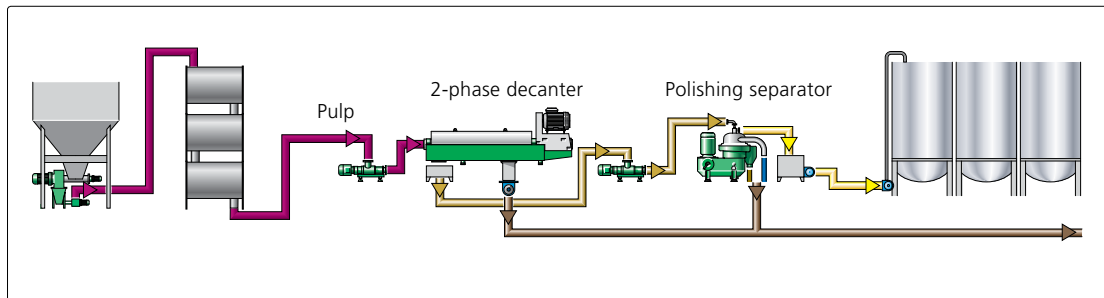

2-phase process

Process system	2-phase system	3-phase system
Extraction rate	Similar to 3-phase	Similar to 2-phase
Dilution water	0 – 5 %	20 – 50 %
Moisture in decanter solids	60 – 65 %	50 – 60 %
Amount of solids relative to raw material	approx. 80 %	50 – 60 %
Amount of waste water relative to raw material	max. 5 %	50 – 80 %
Mesh size	5 – 6 mm	6 – 8 mm
COD value of waste water	5 – 10 g/l	40 – 60 g/l

Continuous or Batch Process

Depending on the company and the sales structure, olive oil can be produced using a continuous method or a batch process. GEA Westfalia Separator has developed individual process lines to provide optimum support for both methods.

Continuous method

With this method, the olives are delivered by tractor or truck and are washed immediately before they are stored in huge silos for a maximum of 48 hours. Alternatively, olives of one particular type are delivered continuously and spend just a short time in the silo. From the silos, the olives are continuously fed into the process. The oil produced is fed into storage tanks and sold by the oil mill. The olive farmers are paid according to the quantity of olives and the oil content. The continuous method is suitable for collective operations in centralized markets and for uniform olive types.

Batch process

In a batch process, the farmers deliver their olives in large sacks or plastic boxes. The olives are processed in batches directly, with no intermediate storage. The farmer thus receives the oil from the olives he has grown himself. A batch process is used in areas where growing and processing are very decentralized and the system is based on the olive oil producers.

GEA Westfalia Separator 2-phase or 3-phase systems can be used for both methods of production. The crucial difference in the process lines lies in the number and dimensions of the malaxers. While only relatively large series of malaxers are used in the continuous method, for the batch process several small, independent malaxers are used in parallel. This enables each olive farmer to have his olives processed separately from the other farmers and there is no chance of the olive batches being mixed.

The major advantage of the GEA Westfalia Separator Group solution lies in the fact that the malaxers for a batch system can be individually heated rather than in groups. This means that the desired product quality can be reliably ensured in every single batch. In addition, there are no energy losses, for example if only one malaxer is in operation. Because a batch system necessarily involves setup times when changing to a new batch, the line output is around 10 to 20 percent less than that of a continuous method.

- Use of 2-phase or 3-phase systems possible for both methods
- Individual heating of malaxers in batch method for optimum product quality and precise use of energy for the process

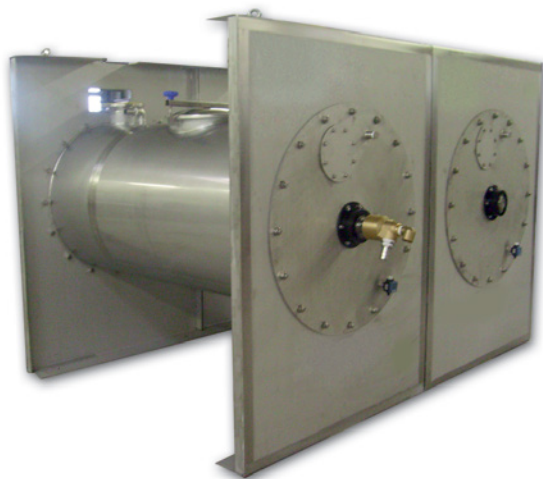

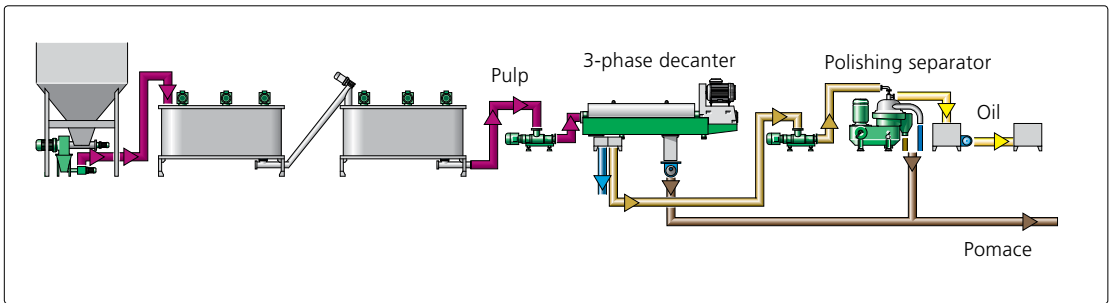

Continuous method with 3-phase decanter

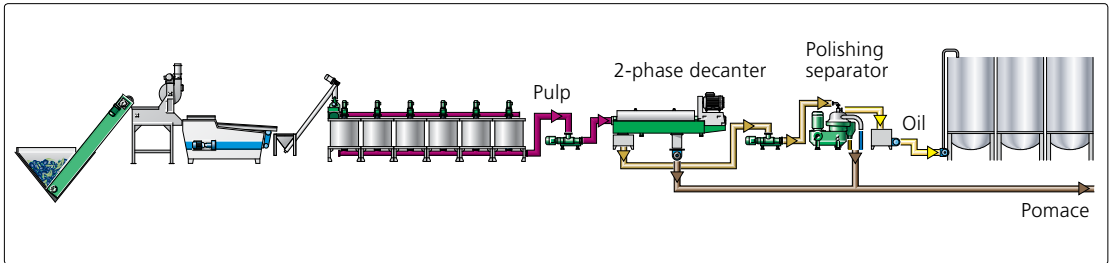

Batch process with 2-phase decanter



Repasso, Pomace and Process Water Treatment

Further treatment of pomace and process water with process lines from GEA Westfalia Separator Group provides additional profitability from the overall olive oil production process.

Pomace treatment in a second decanter stage

In traditional 3-phase systems, the de-oiled pomace is dried and any residual oil is extracted using hexane. The remaining pomace is primarily used as a fuel. However, as the oil extracted with hexane can only be used as a foodstuff after refining, olive oil producers have a considerable interest in installing a second decanter stage for treatment of the pomace. This additional stage is able to recover 40 to 50 percent of the olive oil remaining in the pomace, thus increasing profitability. Separating the pomace into olive pits and pulp also provides valuable by-products. While the pits can be used as a high quality fuel, for example in the oil mills themselves, the pit-free pulp can be dried and then sold as fertilizer or high-fibre feed additive. This pomace treatment is possible in both 2-phase and 3-phase systems.

Prompt treatment of the pomace is known as the repasso process. The quality of the pomace oil obtained is usually not much lower than that of the native olive oil. Alternatively, the pomace can be collected, stored for several months and continuously processed through the year. The oil obtained in this case is of lower quality and therefore more expensive and complicated to refine than repasso oil.

Process water treatment using the Borrass method

GEA Westfalia Separator Group has developed a special decanter process, which can be used to specifically treat the process water. Although the 2-phase technology does not require any dilution water, other stages of the process – as with any process – do consume water. Around 200 litres are required per ton of olives processed. This water then becomes waste water. If it is concentrated by sedimentation or flotation, it is referred to as residual sludge (Spanish “borras” = sediment). A 3-phase decanter with a high level of separation then separates out the residual oil and extremely fine particles from this residual sludge. Overall, the Borrass process has three key advantages. Firstly, it reduces the volume of waste water by 15 percent. Secondly, all of the parameters relevant for assessment of the waste water fall, resulting in lower waste water charges. Thirdly, the oil mill gains up to an additional 0.5 percent of oil relative to the quantity of olives processed.

- Gain of additional oil with identical quality
- Saleable by-products
- Reduction in waste water volume

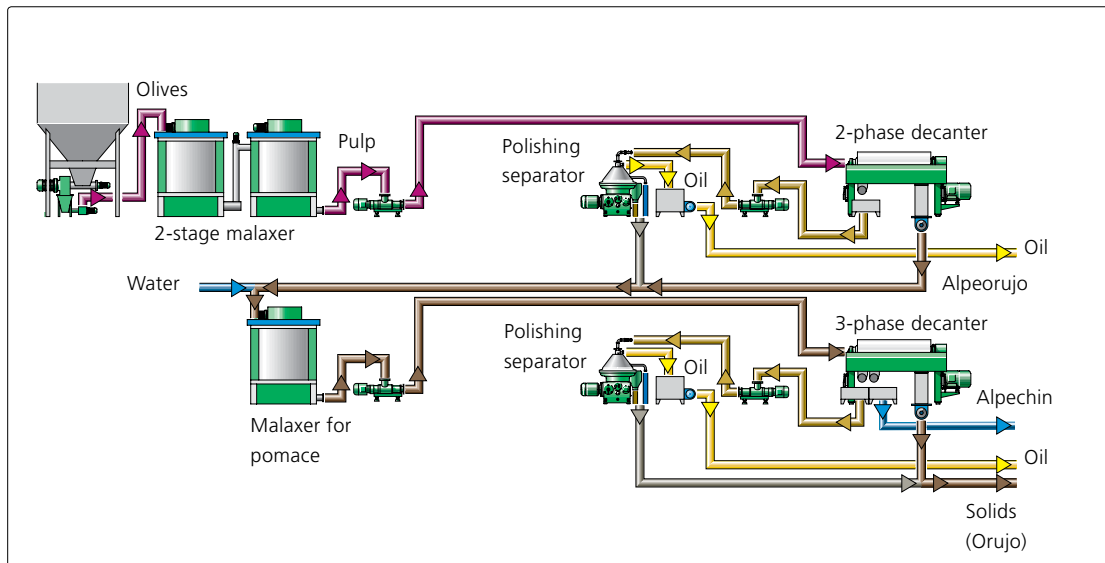

2-phase oil production combined with 3-phase repasso process



Acceptance and Cleaning

As a system partner, GEA Westfalia Separator supplies complete process lines. These include all components for acceptance and cleaning of the olives.

Before the olives can be milled, they need to be weighed, washed and cleared of stems, leaves and other vegetable and non-vegetable matter. GEA Westfalia Separator Group supports the olive oil business with proven components for every step in the process.

For acceptance of the olives, special scales are available, allowing the olives to be weighed quickly and accurately. Cleaning machines reliably remove all stems and leaves that are still attached to the fruits. Appropriate washing systems are also of vital importance for cleaning the olives of any dirt or soil, ensuring that the oil is of optimum quality.

GEA Westfalia Separator Group supplies all of these components. Because everything comes from the same supplier, the systems are perfectly compatible. Production runs smoothly, reliably and quickly, from start to finish.

GEA Westfalia Separator Group supports you with

- Acceptance hoppers
- Conveyor belts
- Cleaning machines
- Washing machines
- Scales
- Stick removers



Mills

Various mill models are available, which can be optimally adapted to local conditions.

The pre-treated olives are reduced in hammer mills and milled to form olive pulp. Hammer mills are used because they are the best suited solution for the heterogeneous mixture of soft fruit flesh and hard pits. A rotor with moving steel hammers rotates at high speeds in a metal housing. The olives are fed into the impact zone of the rotor, where they are crushed by the steel hammers. The mixture of fruit flesh and pits remains in the reduction zone until it fits through a perforated strainer at the mill outlet. The perforation size can be varied by using different strainers.

GEA Westfalia Separator supports operators whatever their requirements and physical constraints with appropriate mill models. For continuous operation, the mills are often installed directly underneath the silos, and the olive pulp is normally transported to the malaxers by pumps. For a batch process, the mills can be attached directly to the malaxers, which eliminates the need for transportation.

- ASingle mills
- Double mills
- Stand alone installation
- In combination with malaxer
- Centralized or decentralized
- Screw conveyors
- Rotating or stationary strainer





Malaxers

Malaxers from GEA Westfalia Separator Group are individually adjusted for a continuous or batch process. This ensures the required product quality and optimizes the use of energy.

Before the pulp can be fed from the hammer mill to a decanter, it must pass through a malaxing process. This process, in which the pulp is stirred at a particular temperature for a specified period of time, leads to an additional breakdown of the cells. The proportion of free oil is increased and the oil droplets can flow together to form larger droplets. GEA Westfalia Separator Group supplies the necessary malaxers for this stage. While the continuous production process uses a small number of large malaxers, the batch process uses several small malaxers, as the batches belonging to the different growers need to be kept separate.

Batch malaxers from GEA Westfalia Separator Group can be individually heated. The advantage of this is that the heating can be adjusted to the specific volume of the relevant batch, ruling out the possibility of

overheating with the resulting detrimental impact on quality. In addition, individual heating cuts energy losses, which are possible with complete heating if the full capacity of the malaxers is not being used.

GEA Westfalia Separator Group supports you with

- Malaxers for continuous processing
- Malaxers for batch processing – individually heatable
- Horizontal and vertical agitating
- Malaxers for manual and automatic operation

Benefits of malaxers from GEA Westfalia Separator Group

- High energy efficiency, due to individual heating
- Level monitoring
- Optimized usage, particularly for production of cold pressed olive oil

Accessories

GEA Westfalia Separator also supplies supplementary accessories, from vibrating strainers and centrifuge platforms through to buffer and pure oil tanks for appropriate storage of olive oil products.

GEA Westfalia Separator Group's product range includes all of the required accessory components, for 2-phase or 3-phase separation and using a continuous or batch process.

Vibrating strainers are used to filter out slight impurities such as very fine lees. GEA Westfalia Separator Group vibrating strainers are designed for 2-phase or 3-phase operation as required.

Also available as accessories are pure oil tanks for intermediate storage of the olive oil following 2-phase or 3-phase separation. The pure oil tanks from GEA Westfalia Separator Group feature high quality materials and optimum hygiene conditions.

- Vibrating strainer for 2-phase and 3-phase operation
- Centrifuge platform – with and without pipelines
- Buffer tank – for decanters and / or separators in a batch process
- Pure oil tank with one or two chambers, following 2-phase or 3-phase separation
- CIP stations



Decanters

2- and 3-phase decanters from GEA Westfalia Separator set standards for reliability and profitability.

Decanters are at the heart of every modern process line. The 2-phase and 3-phase decanters from GEA Westfalia Separator Group are the result of more than 120 years of experience in the development of centrifuges. Innovations such as the 2-phase separation process, GEA Westfalia Separator **cetec** technology and the combined scroll are constantly reinforcing our technological leadership in the market. As well as increased product yield, olive oil manufacturers in all growing countries particularly value the durability of our decanters, which is of vital importance in load intensive campaign manufacture. Long service life and constant availability make GEA Westfalia Separator Group's developments the first choice worldwide. Depending on the required capacity, models for processing between 20 and 240 tons of olives per day are available.

Our developments feature impressive technological features such as the patented 2-gear drive. This drive type allows automatic torque measurement and differential speed regulation. 2-gear drive is so highly recommended because it enables the lowest possible residual moisture in the solid output from the decanter to be achieved. Even with fluctuations in production, a uniform dry substance content can be maintained. In addition, the throughput is higher than using decanters with a standard drive. You can choose from decanters with GEA Westfalia Separator **cetec** technology, standard or combined scroll. The outstanding benefit of the GEA Westfalia Separator combined scroll is that the change to a 2-phase process does not result in any drop in output.

All the advantages at a glance

- 2-phase and 3-phase decanters
- Standard or combined scroll
- 2-gear drive
- Low vibration operation, leading to excellent reliability
- Robust quality, Made in Germany
- Long service life and maximum availability
- Easy operation and monitoring
- High efficiency – rapid amortisation
- Maximum product yield
- GEA Westfalia Separator **cetec** technology for 1 – 2 percent additional oil yield
- Conversion from 3-phase to 2-phase process with GEA Westfalia Separator with identical throughput

Advantages of the 2-phase process

- No addition of dilution water necessary in most cases
- The olive oil obtained in the 2-phase process contains all natural constituents of oil (polyphenols), giving the oil a more intense taste
- Solid/water mixture can be processed relatively easily (e. g. for pit separation, water separation and olive oil recovery)
- No separate waste water phase in decanter

Advantages of the 3-phase process

- Solids are easy to transport
- The solid quantity is only 50 % of the feed quantity
- Established infrastructure for processing of solids in traditional industry

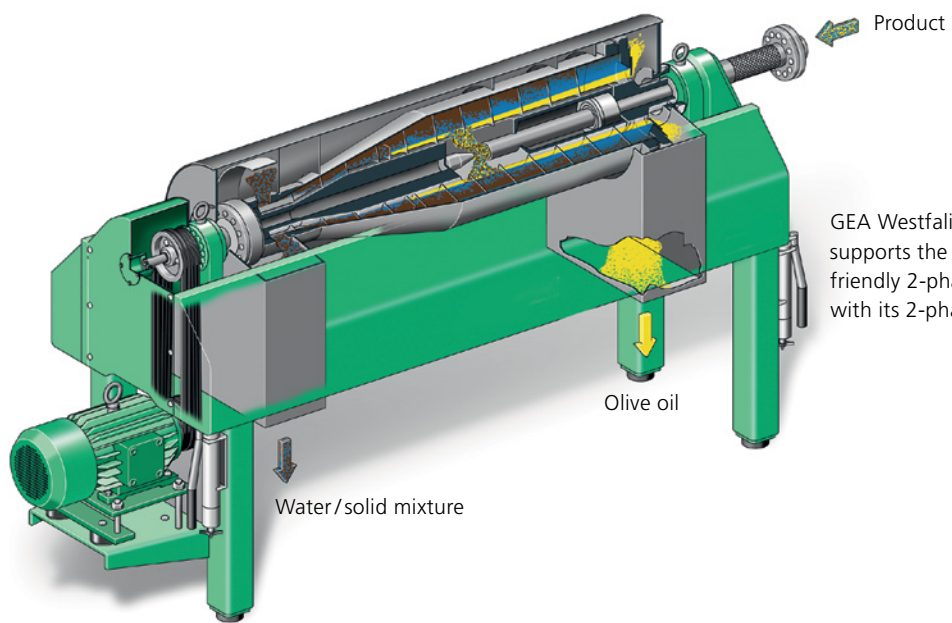

GEA Westfalia Separator Group supports the environmentally-friendly 2-phase process with its 2-phase decanters.

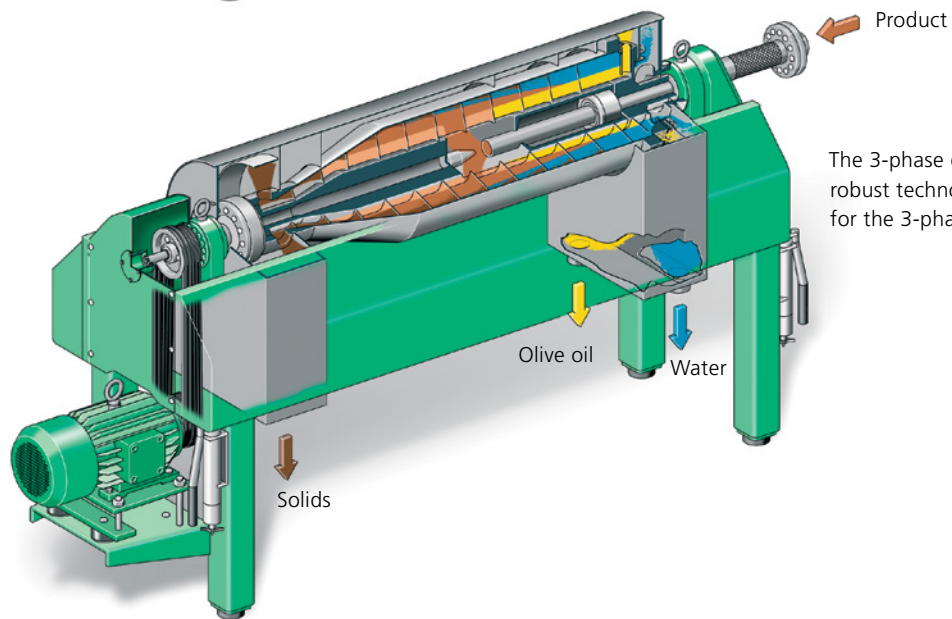

The 3-phase decanter – robust technology for the 3-phase system

Separators

Polishing separators from GEA Westfalia Separator ensure the required premium quality by removing all residue while handling the product with extreme care.

The separated olive oil from the decanter still contains residual water and extremely fine lees material. Therefore, the oil phase is polished by a separator after the decanter. Once again, GEA Westfalia Separator Group equipment is state of the art here. The self-cleaning models reduce maintenance costs to a minimum, while handling the oil with the utmost care and using the GEA Westfalia Separator hydrostop system to ensure optimum product yield and solids almost totally free of oil.

The oil is purged of the lees and water in the disk stack. The separated heavy liquid phase (water) drains freely out of the bowl through the separating disk. The cleaned light liquid phase (oil) is discharged under pressure via centripetal pump. The centrifuged solids collect in the solid chamber and are discharged at periodic intervals.



The patented GEA Westfalia Separator hydrostop system ensures that during the partial ejection – when the bowl is open for a sufficiently short time – no product losses can occur. Only the collected solids are discharged, the oils remains inside the bowl where it is polished. The bowl can be cleaned manually or automatically using the PLC system, which involves complete emptying of the bowl.

- GEA Westfalia Separator hydrostop system for minimum oil losses
- Self-cleaning effect after total ejections
- Improved clutch design for a longer wear lifespan
- All parts coming into contact with the product are made of stainless steel
- Flat-belt drive design
- Higher g-force
- Automated operation
- Continuous processing mode
- Simple maintenance
- Low noise design

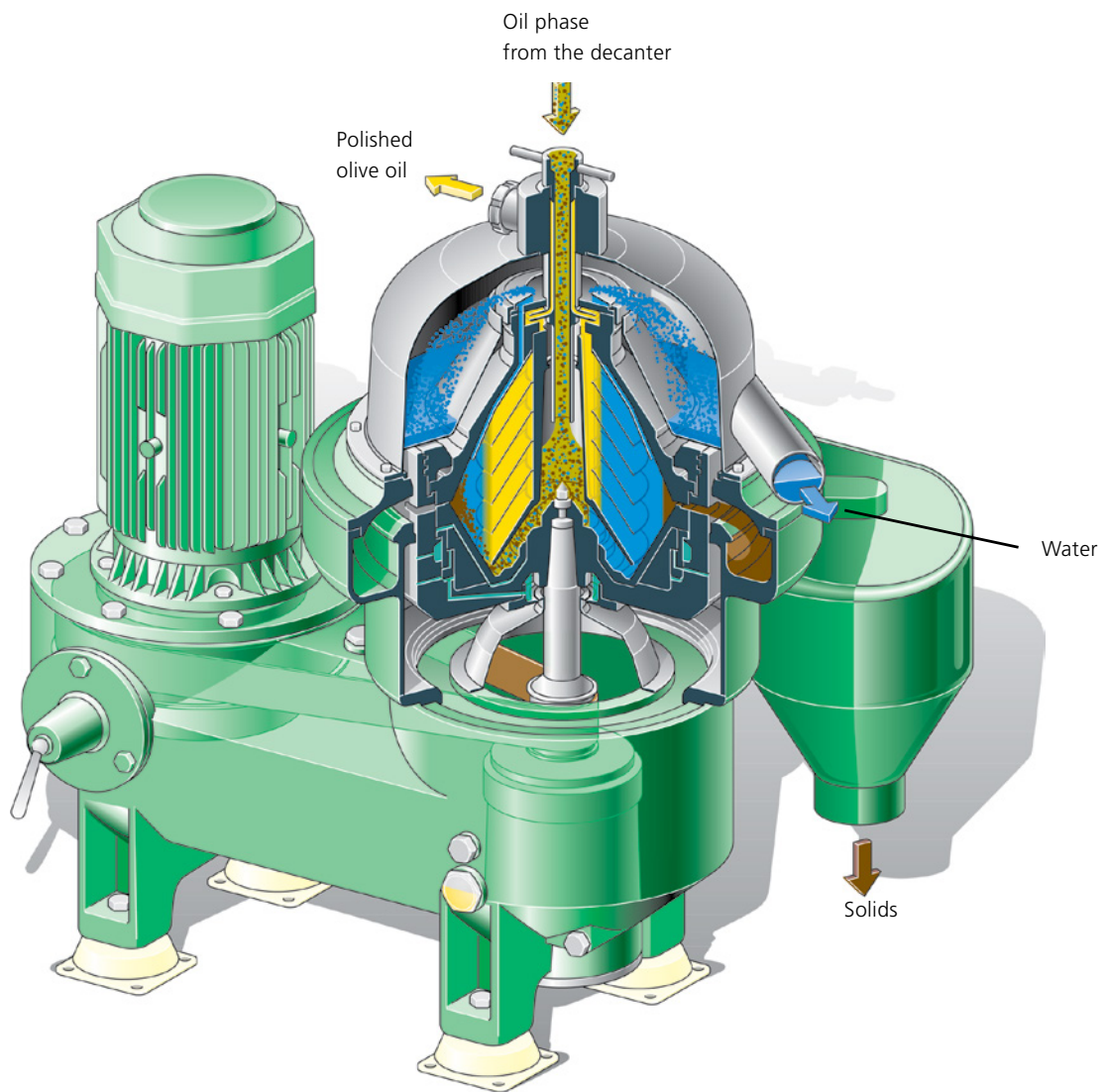

Thanks to its excellent separation effect, the polishing separator makes for maximum product yield.



serv&care – Proactive Service for Optimum Reliability on-site

The proactive, risk-free services of serv&care optimize operating reliability and permanent availability of the drive systems.

Safety first: this is precisely what the service concept serv&care stands for.

Customers not only benefit from traditional services such as inspection, maintenance, original spare parts and repair work provided by the original manufacturer; they also benefit from proactive solutions which avoid risk, e.g. online and offline monitoring with GEA Westfalia Separator wewatch®. These preventive services are the best pre-condition for a smooth operation.

Enhanced process efficiency also follows from maximum operating reliability and machine availability. Accompanying modernization or upgrading to state-of-the-art technology also offer the option of boosting performance as required.

Training provided on site or in the modern training centre of GEA Westfalia Separator Group ensures that the plant operator's employees receive training in the proper handling of the high-tech installations. This provides additional safety.

Authorized workshops worldwide

And if problems occasionally occur or if a spare part is required at short notice, the specialists are able to attend to the ships quickly. This is ensured by a global network with more than 50 sales and service companies. Authorized workshops are able to service every location in the world at short notice.



serv&care

serv&care accordingly makes for maximum operating reliability, machine availability, process efficiency and budget security. And these benefits are provided throughout the entire life cycle of the entire installation.

In addition to traditional services such as maintenance or repair, serv&care also provides solutions which avoid risk and with which the installation availability can be proactively assured.

Service from the original manufacturer:

- Service engineers quickly on site
- Extensive service network
- Risk avoidance through service provided by the original manufacturer
- Proactive solutions
- Upgrading to boost performance
- Crew training



We live our values.

Excellence • Passion • Integrity • Responsibility • GEA-versity

GEA Group is a global engineering company with multi-billion euro sales and operations in more than 50 countries. Founded in 1881, the company is one of the largest providers of innovative equipment and process technology. GEA Group is listed in the STOXX® Europe 600 Index.

GEA Mechanical Equipment

GEA Westfalia Separator Group GmbH

Werner-Habig-Straße 1, 59302 Oelde, Germany
Phone: +49 2522 77-0, Fax: +49 2522 77-1794
www.gea.com

