



GEA FILLASEPT® IBC FILLING SYSTEM

IBC filling for demanding applications

Our contribution for your process and product safety

Description

The fillasept® IBC Filling System is a plug & play solution for the filling of IBC modules (Intermediate Bulk Containers) under enhanced hygienic requirements. The system is especially distinguished by its compact design, the easy connection to industrial processes as well as the smooth adjustment of process parameters to the product to be filled.

The interface between the filling system and IBC is formed by a specifically designed filling head. The interspace in the connection area is impeccably rinsable and sterilizable. The rinsing happens with hot water, which is provided directly at the module by an integrated tubular heat exchanger. For the user, this means thorough, supervisable security of the filling process.

In the basic configuration the programs production, SIP / CIP and rinsing are firmly deposited. Process parameters such as sterilization, filling and rinsing time as well as fill quantity and CIP data can be freely configured in the corresponding submenus. The fill quantity monitoring happens via a scale integrated into the manual lift truck. The values are continuously and wirelessly transmitted to the control system and evaluated and they hence allow the accurate filling of the respective container. The easily understandable Graphic User Interface of the integrated PLC enables a simple access to the relevant data.



Compatibility and adaptability

Type H1 = Adjustable height
191 – 391 mm, angle +/- 30°

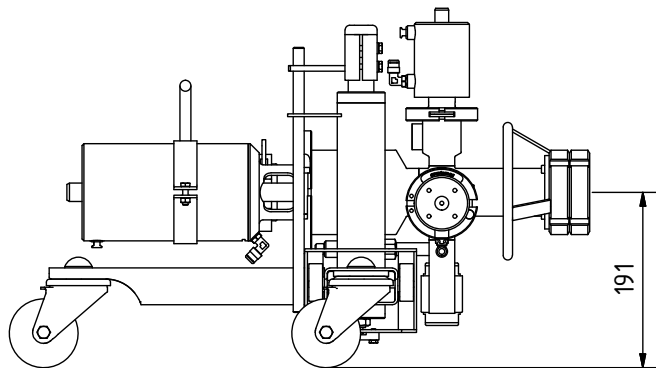

Type H2 = Adjustable height
416 – 616 mm, angle +/- 30°

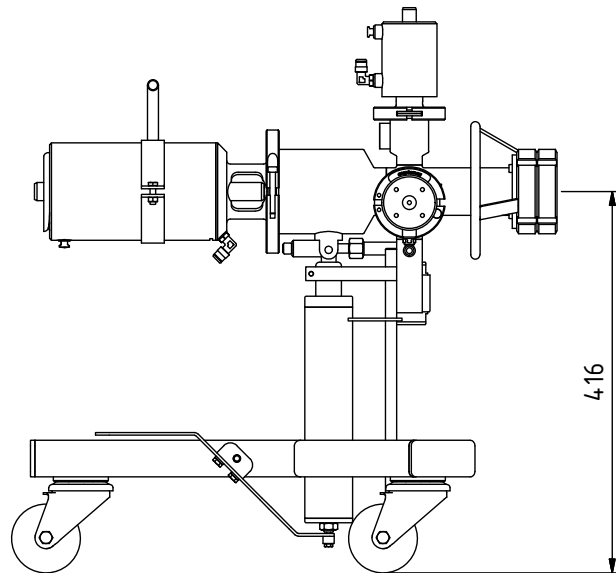

Compatibility

The fillasept® IBC Filling System can basically be used with any bag-in-box system. For a filling under enhanced hygienic requirements, the bag needs to include a steam-sterilizable shut-off valve, which is ideally located at the bottom end of a bag side.

Adaptability

The fillasept® IBC Filling System in its standard execution already covers a wide range of applications. By making use of the available options, the system can further be adapted to your needs.

System design options

- Increased filling capacity (double filling head)
- Other pipe sizing and connection standards
- Various feedback options available (open feedback, T.VIS® etc.)
- Field bus connection ASI / DeviceNet
- Alternative PLC according to customer request
- Customized process programming

Lift truck for filling head

The lift truck is a device that enables simplified handling of the filling head. The filling head is mounted on an hydraulic cylinder and thanks to the integrated joint it is not just adjustable in height, but also adaptations of the angle are possible.

Main components

Filling head

Special filling head design with impeccably rinsable and sterilizable interspace in the connection area.



Control system

The integrated PLC enables simple access to the relevant data as well as seamless integration into the plant PLC.



Media handling

The different sub-systems for process media and product – including an integrated tubular heat exchanger for hot water treatment – provide everything that is needed for the safe and efficient operation of the filling head.



Technical data

Connection and dimensioning

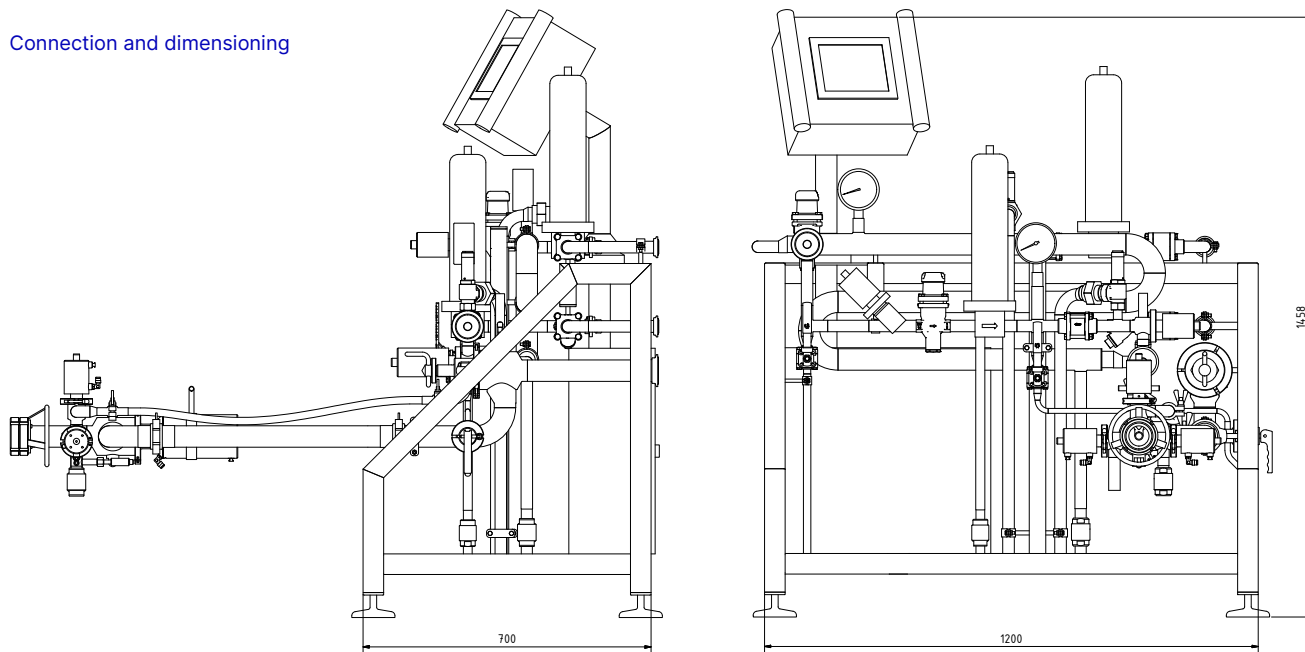

| | |
|--------------------------------|---------------------------------------|
| Nominal diameter | DN50 |
| Operating temperature | 0 – 150 °C |
| Nominal pressure | 6 bar |
| Dimensioning (L × W × H) | 1,200 × 700 × 1,460 mm |
| Bin sizes | 100 – 1,000 L |
| Filling capacity | Appr. 6 bins of 1,000 L/h* |
| Product loss / filling | 0.65 L |
| Product valves | GEA Aseptomag® |
| Valves for process media | Sanitary valves |
| Sealing materials | FDA approved |
| Square pipe frame | AISI 304 |
| Parts in contact with product | AISI 316L, $R_a \leq 0.8 \mu\text{m}$ |
| Supply voltage | 100 – 230 V AC |
| Monitoring of filling capacity | Integrated scale |
| Communication | Wireless connection |

* Depending on product and process

GEA Aseptomag AG
Industrie Neuhof 28
3422 Kirchberg, Switzerland

Tel +41 34 4262929
Fax +41 34 4262928